

Flick the switch on lower position, line will pay out 3 feet and then release for free drop to depth required. When enough line is out, flick the switch to raise, bring in about 3 feet of line and release switch; this automatically locks line in raise or hold position.

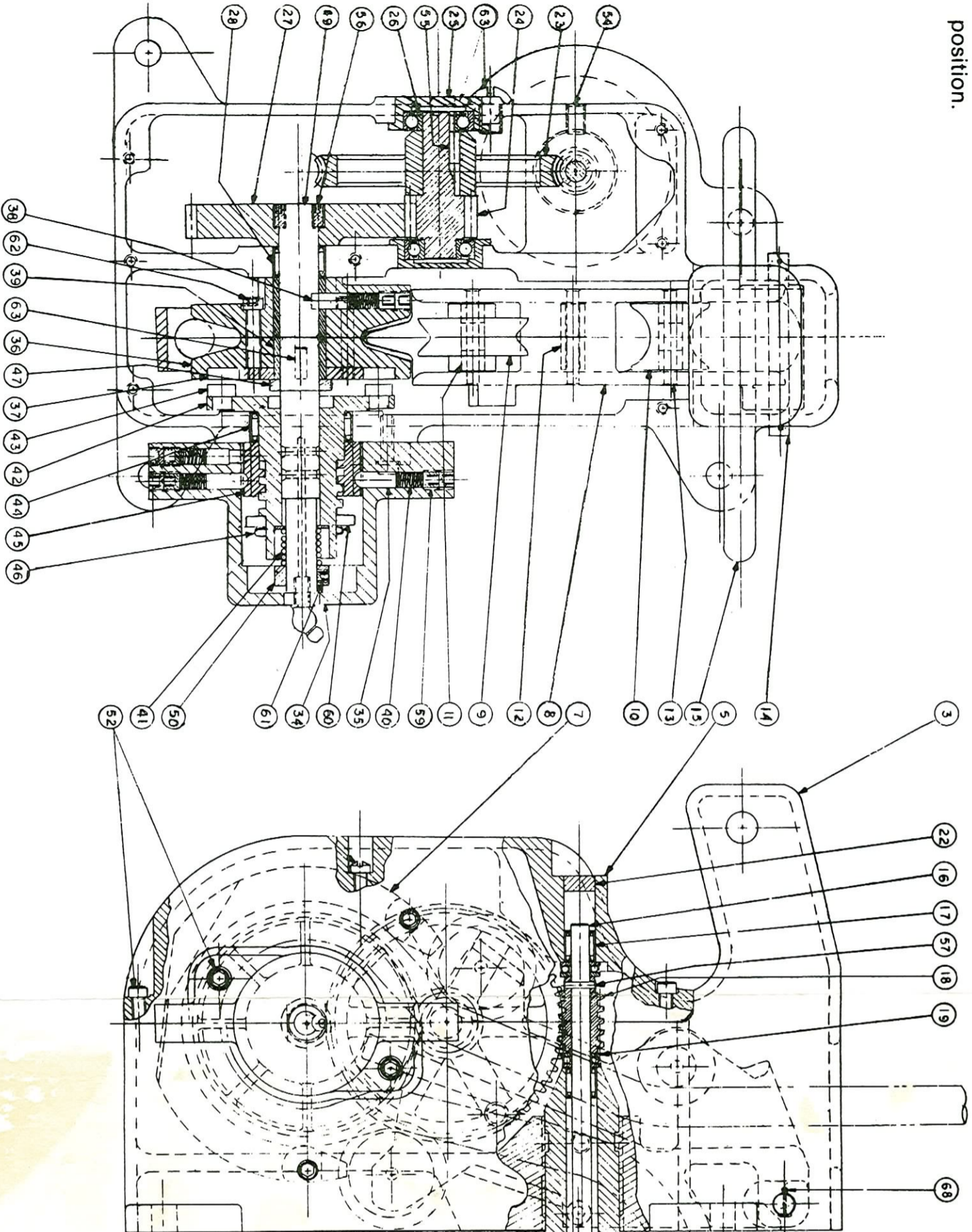

PARTS LIST — FREE WHEELING MODELS

“IMPORTANT NOTE”

When ordering replacement parts Please Specify “AFD” (1/2” model) or, “CFD” (5/8” model)

- 1- Remove set screw #59 (2 places) to release spring tension.
- 2- Remove housing #34 (2 screws) and slide housing off.
- 3- Release nut #45 should turn freely away from side of casting to side of teflon washer #60. This nut must turn freely in this area.
- 4- Clean springs #40 and pins #35 and all other parts.
- 5- Lubricate assembly with Lubriplate 1200-2 (Boat trailer wheel bearing) grease. Re-seal housing #34 to windlass using clear Silicone sealer and 2 screws (#52).
- 6- Replace pins #35 and springs. Adjust set screws approximately flush with housing and stake to prevent coming out.
- 7- This should be checked seasonally to remove corrosion and salt from clutch.

QTY	PART NO.	DESCRIPTION	MATERIAL	SH. NO.
2	1/16 Dia x 1/2 Lg	SCREW	STAINLESS	
1	Support Collar		STAINLESS	
2	3/16 Dia x 3/4 Lg	Dowel Pin	STAINLESS	
2	10-24 x 1 1/2 Lg	Soc. Hd Cap Scr.	STAINLESS	
1	10-24 x 3/16 Lg	Soc. Hd Cap Scr.	STAINLESS	
2	STOP COLLAR		NYLON	
8	5/16-18 x 1/4 Lg	Soc. Hd Scr.	STAINLESS	
2	10-32 Hex. Nut		STAINLESS	
1	110 Dia x 1/2 Lg	Pin	STAINLESS	
2	1/20 x 1/2 Lg Soc. Hd Scr.		ALLOY	
1	Key 1/32 sq		DRILL ROD	
1	5/16-18 x 1/2 Lg	Soc. Hd Scr.	STAINLESS	
1	3/8-16 x 1/2 Lg	Soc. Hd Scr.	STAINLESS	
10	10-24 x 3/4 Lg	Soc. Hd Cap Scr.	STAINLESS	
1	Retaining Ring		STAIN 303	
1	Spacer		STAIN 303	
1	Retaining Ring		STAIN 303	
1	Release Nut		WHITE DELRIN	
4	Bushing		BRONZE	
2	Drive Pin		BRONZE	
4	Clutch		STAIN 302	
4	Spring		STAIN 302	
1	Bushing		OLITE	
1	Plate		ALUM. BRZ	
1	Sprocket		ALUMAG #35	
1	Cover		ALUMAG #35	
1	Bearing		NEEDLE #1108	
1	S-Gear		C-1117	
1	Bearing		BALL #55RPP	
2	Cap		ALUM. 2024-T4	
1	P-Gear		A1.S1. 4130	
1	Plug		BRONZE	
1	Motion		ALUM. 2024-T4	
1	Housing		12 VDC. REV.	
2	Bearing		THRUST #A08	
1	Worm		HVH	
3	Bearing		NEEDLE #855	
1	Shaft		STAIN. 303	
1	Pin		ALUM. 2024-T4	
1	Knurled Pin		STAIN. 303	
4	Roller		WHITE DELRIN	
1	Roller		WHITE DELRIN	
1	Roller		WHITE DELRIN	
2	Rocker Arm		ALMAG #35	
1	Hope Ring		ALMAG #35	
1	Case Cover		ALMAG #35	
1	Assembly			

MODEL C FREE WHEELING
 GOOD AUTOMATIC WINDLASS
 500
 SH. T. No. 1 OF 12

NO.	REVISION	DATE BY
1	PART NO. 36 REVISED	6-5-70/LL
2	GENERAL REVISION	